

Glastender®

A family company manufacturing in the USA

www.glastender.com



C1SB24 with compressor left, stainless glass door, and stainless top

CONFIGURATION HIGHLIGHTS



Intertek

EP 5016978
Energy Performance
Verified / Rendement
Énergétique Vérifié



Intertek

4004503
Conforms to NSF/ANSI STD 7
and UL STD 471
Certified to CSA STD C22.2 No. 120
Listed to NSF Standard 7
for open food as a storage refrigerator



Intertek

Standard Features

- Locking door(s)
- LED interior lighting
- Heated mullion to minimize condensation
- Any door opening may be converted to a drawer section or to draft dispensing
- Available without a finished top for integrated installation below customer supplied bar top
- 180° swinging door

Draft Beverage Compatible



See page 3 of this spec for a complete list of cooler accessories.

Specifications

Electrical

- 120V, 1 phase, 60 Hz
- Full load amps - 2.75
- Dedicated 15 amp circuit is required
- Includes a 6 foot NEMA 5-15P grounded cord and plug which exits the back of refrigeration compartment

Refrigeration

- R290 - 105 grams
- Compressor - 1/8 HP
- Heat rejection - 1126 BTU/Hr

Operating Range

- 34°F (1°C) to 40°F (4°C)

Plumbing

- Automatic condensate evaporator. No drain connection required.



5-15P

Shelving

- Three adjustable coated shelves per door included (does not include sections with drawers or pull-out wine shelves)
- Two to six pull-out wine shelves per door optional

Materials

- Stainless steel parts include: exterior sub-top, interior, front of cabinet, hinges, hinge and lock brackets, and optional legs
- Black vinyl-clad steel parts include: standard sides, doors and compressor cover
- Galvanized steel parts include: back and bottom
- Zinc plated CR steel parts include: leg sockets

Weight Bearing Capacity

- Counter tops and other accessories should not exceed 500 pounds per door

Project: _____	AIA# _____
Item #: _____ Qty: _____	SIS# _____
Model #: _____	

Coolers, One Zone, Side Serviced, Bar Profile

C1SB24, C1SB28, C1SB36, C1SB44, C1SB48

C1SB Configurable Options

Temperature:

- Beer/Food - 34°F to 40°F
- White wine - 50°F to 55°F
- Red wine - 60°F to 65°F

Refrigeration Compartment

Location:

- Left or Right

Refrigeration Compartment

Cover Finish:

- Black vinyl-clad
- Stainless steel
- Jeweled stainless

Door/Drawer Style & Finish:

- Door - Black vinyl-clad
- Door - Unlaminated
- Door - Stainless steel
- Door - Jeweled stainless
- Door - Laminated
- Door - Glass, black vinyl-clad
- Door - Glass, stainless steel
- Door - Glass, jeweled stainless
- Door - Glass, laminated
- Drawers - Black vinyl-clad
- Drawers - Unlaminated
- Drawers - Stainless steel
- Drawers - Jeweled stainless
- Drawers - Laminated

Door Hinge Location (specify for each door):

- Left or Right

Shelving (specify per door section, wine shelves not available on 12" door opening models):

- Three adjustable shelves
- Keg Rack
- Pull-out wine shelves:
 - » w/combination upright and horizontal storage
 - » w/upright storage
 - » w/horizontal storage

Door Handle: (Note: drawers come with a stainless pull tab handle)

- Polished stainless
- Polished brass
- Stainless pull tab

Top Style:

- No finished top
- Stainless top
- Laminated top

Left and Right Side Finish:

- Black vinyl-clad
- Stainless steel
- Laminated

Back Finish:

- Galvanized steel
- Stainless steel

LED Lighting Style:

- Bright white (7,000k)
- Warm white (3,500k)
- Amber (2,700k)
- Blue

Glastender, Inc. • 5400 N Michigan Rd • Saginaw, MI • 48604-9780
989.752.4275 • 800.748.0423 • Fax 989.752.4444
www.glastender.com

Approval/Notes:

Specifications subject to change without notice. For current specifications please visit our website.

Coolers - One Zone, Side Serviced, Bar Profile

Dimensional Information

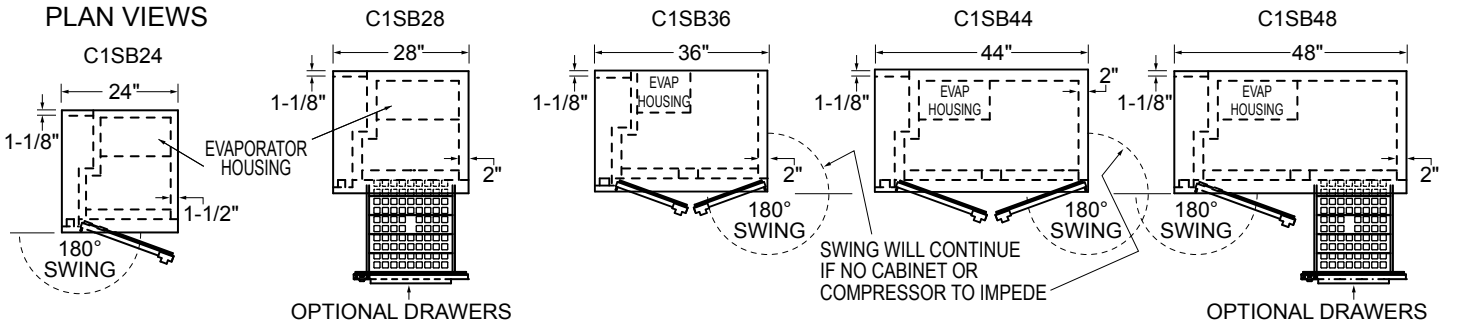

FRONT VIEWS

*ADD 1" HEIGHT TO TOP FOR FACTORY INSTALLED TOP

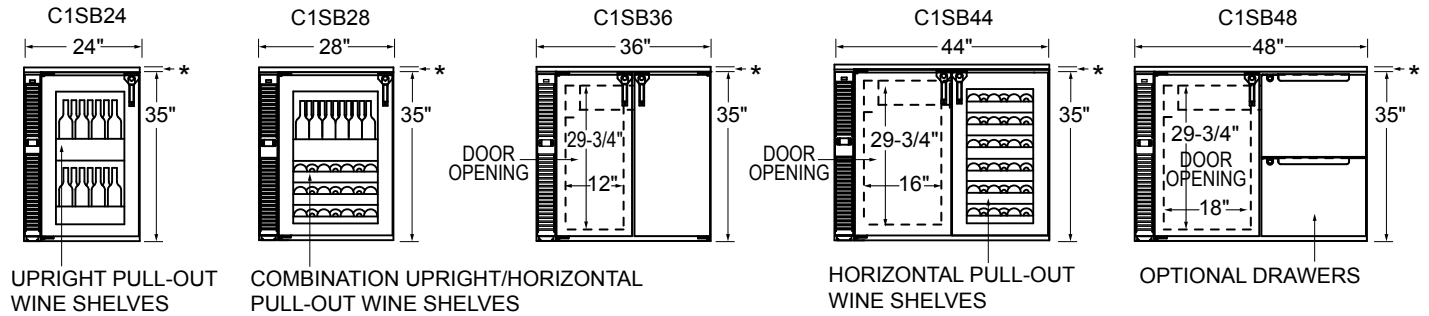

SIDE VIEWS

*ADD 1" HEIGHT TO TOP FOR FACTORY INSTALLED TOP

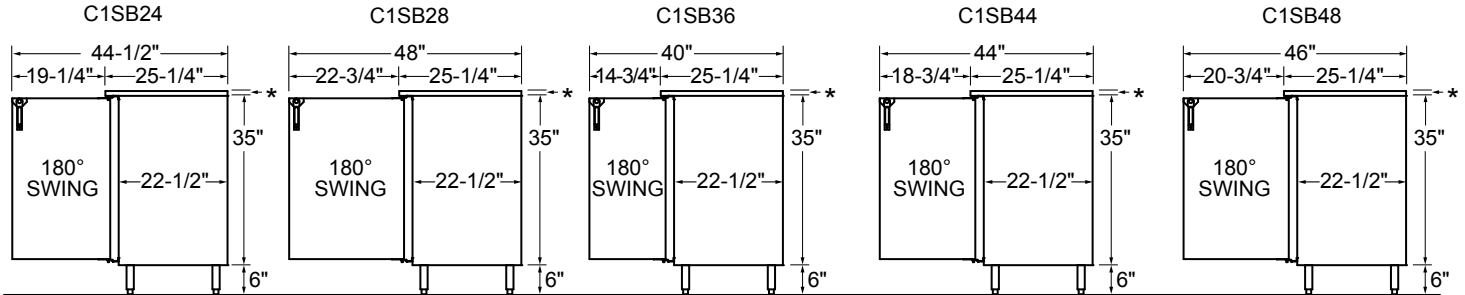

ALL MODELS SHOWN WITH OPTIONAL 6" LEGS

Note: Available with compressor left or right. Compressor left model shown.
*Wine bottle capacity is based on adjustable shelves. Drawers will hold less.

Model	DOORS	Capacities			
		12 oz. bottles, cases	750ml wine bottles*	1/2 barrel kegs	1/6 barrel kegs
C1SB24	1	5.8	50	1	3
C1SB28	1	6.6	60	1	4
C1SB36	2	8.9	92	N/A	5
C1SB44	2	12.0	116	N/A	7
C1SB48	2	13.2	137	2	8

SIDE VIEWS

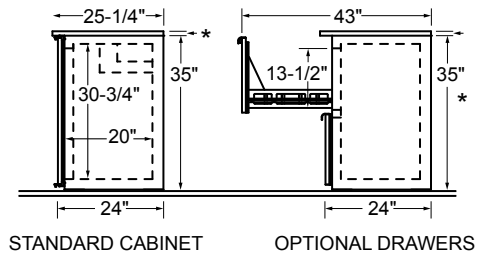

OPTIONAL LEGS AND CASTERS

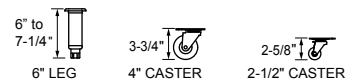

5400 N Michigan Rd • Saginaw, MI • 48604-9780
989.752.4275 • 800.748.0423 • Fax 989.752.4444
www.glastender.com

Printed in USA

Direct Draw Draft Beverage Towers and Accessories

Configuring Bar Profile Coolers for Draft Beverage Dispensing

All Glastender bar profile coolers can be configured for draft beverage dispensing. Please note that a minimum 17" wide door opening is required for full size (i.e., 16" diameter) 1/2 barrel kegs. Refer to the capacity statements in the Product Directory or Specification Sheet for the sizes and quantities of kegs each unit will hold.

Direct Draw Draft Beverage Towers

Glastender Beverage Towers come standard with the stainless steel faucets and shanks necessary to dispense keg beer, wine, soda, coffee, or cocktails. See individual spec pages for complete information.



CT-3-SS

Column Towers
See spec page CT for complete information



BT-4-SS

Tee Towers
See spec page BT for complete information

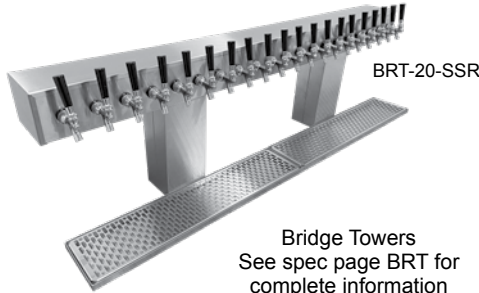

BRT-20-SSR

Bridge Towers
See spec page BRT for complete information



CBT-4-MF

Cobra Towers
See spec page CBT for complete information

Look for the Draft Beer Compatible logo



Tower Cooling Kits

Direct draw beverage towers are chilled by air from inside the host cooler. This is especially important for draft beer, as warm faucets cause the beer to foam.

TOWER COOLING KITS

MODEL	DESCRIPTION	WGT
TCK12-1	For 1 & 2-door coolers w/ one tower column	3#
TCK12-2	For 3 & 4-door coolers w/ two tower columns	6#
TCK34-1	For 3 & 4-door coolers w/ one tower column	8#
TCK34-2	For 3 & 4-door coolers w/ two tower columns	11#

PRIMARY REGULATOR KITS

Primary regulators are used to step down the CO₂ or nitrogen pressure from the main source. A tank mount CO₂ primary regulator attaches directly to the CO₂ tank. A bulk or in-line CO₂ primary regulator is used to splice into a CO₂ line when the CO₂ tank is shared by more than one system. A tank mount nitrogen primary regulator is used with pre-blended nitrogen and CO₂ or pure nitrogen gas. Each primary regulator kit includes 50 feet of nylon braided hose.

MODEL	DESCRIPTION	WGT
PRK-TC	Tank mount CO ₂ primary regulator kit	15#
PRK-BC	Bulk CO ₂ primary regulator kit	15#
PRK-TN	Tank mount nitrogen primary regulator kit	15#

SECONDARY REGULATOR KITS

The REG-CO₂-LP1 secondary regulator kit is normally mounted inside the direct draw cooler and connects to the gas line coming from the externally mounted primary regulator. For installations with more than one keg on tap, also order the appropriate manifold kit(s). When no external source of CO₂ is available, a 5 pound CO₂ cylinder may be stored inside the cooler, which will require the REG-CO₂-HP regulator. A manifold kit will also be required if there is more than one keg on tap.

MODEL	DESCRIPTION	WGT
REG-CO ₂ -LP1	Secondary regulator kit	7#
REG-CO ₂ -HP	Primary regulator kit for use with 5# CO ₂ tank	7#
MAN2	Two product manifold kit	2#
MAN3	Three product manifold kit	3#
MAN4	Four product manifold kit	4#
MAN5	Five product manifold kit	5#
MAN6	Six product manifold kit	6#

ADDITIONAL ACCESSORIES

MODEL	DESCRIPTION	WGT
03004240	1/2" ID black drain line, per foot	N/A
05000400	5/16" ID red vinyl air line, per foot	N/A
05000386	1/4" ID nylon braided air line, per foot	N/A
05001066	Sanke keg tap, stainless steel probe	2#
05001026	Sanke keg tap, low profile	2#
05002019	U system keg coupler w/ss probe for Guinness and Harp	2#
05000368	Lock for beer faucet	2#
05000636	5# CO ₂ tank (unfilled)	15#
LCK	Line cleaning kit	
06007084	Drain bottle	

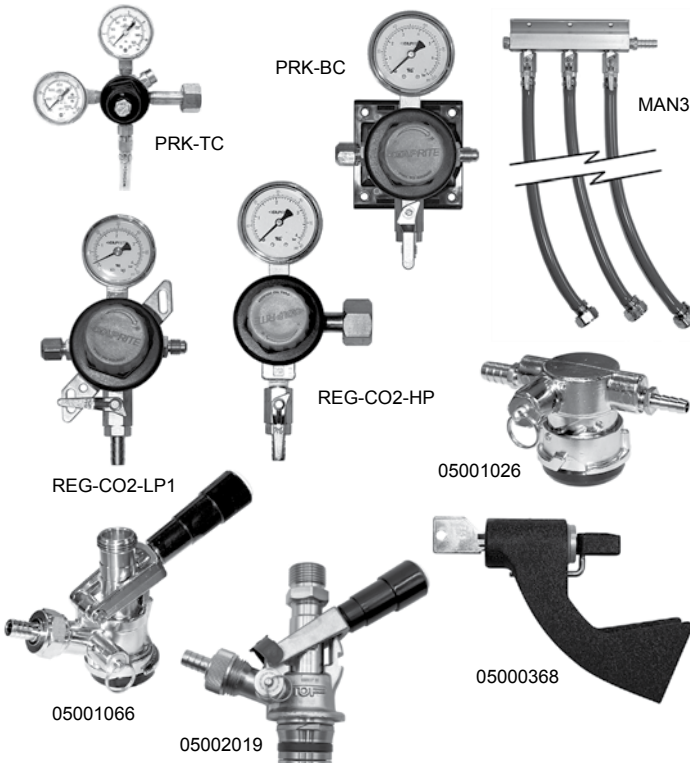

**Glas
tender**

5400 N Michigan Rd • Saginaw, MI • 48604-9780
989.752.4275 • 800.748.0423 • Fax 989.752.4444
www.glastender.com

Printed in USA